

Installation Instructions

IMPORTANT NOTES

1. Failure to install, finish or maintain this product in accordance with applicable building codes, regulations, standards and James Hardie's written application instructions may lead to personal injury, affect system performance, violate local building codes, and void James Hardie's product warranty.
2. All warranties, conditions, liabilities (direct, indirect or consequential) and obligations whether arising in contract, tort or otherwise other than those specified in James Hardie's product warranty are excluded to the fullest extent allowed by law. For James Hardie's product warranty information and disclaimers about the information in this manual, see the section at the end of this manual
3. The builder must ensure the product meets aesthetic requirements before installation. James Hardie will not be responsible for rectifying aesthetic surface variations following installation.
4. Make sure your information is up to date. When specifying or installing James Hardie® products, ensure you have the current manual. If in doubt, or you need more information, visit www.jameshardie.com.au or Ask James Hardie™ on 13 11 03.

WARNING
DO NOT BREATHE DUST AND CUT ONLY IN WELL VENTILATED AREA

James Hardie products contain sand, a source of respirable crystalline silica which is considered by some international authorities to be a cause of cancer from some occupational sources. Breathing excessive amounts of respirable silica dust can also cause a disabling and potentially fatal lung disease called silicosis, and has been linked with other diseases. Some studies suggest smoking may increase these risks. During installation or handling:



- (1) work in outdoor areas with ample ventilation;
- (2) minimise dust when cutting by using either 'score and snap' knife, fibre cement shears or, where not feasible, use a HardiBlade® saw blade and dust-reducing circular saw attached to a HEPA vacuum;
- (3) warn others in the immediate area to avoid breathing dust;
- (4) wear a properly-fitted, approved dust mask or respirator (e.g. P1 or P2) in accordance with applicable government regulations and manufacturer instructions to further limit respirable silica exposures. During clean-up, use HEPA vacuums or wet cleanup methods - never dry sweep.

For further information, refer to our installation instructions and Material Safety Data Sheets available at www.jameshardie.com.au. FAILURE TO ADHERE TO OUR WARNINGS, MATERIAL SAFETY DATA SHEETS, AND INSTALLATION INSTRUCTIONS MAY LEAD TO SERIOUS PERSONAL INJURY OR DEATH.

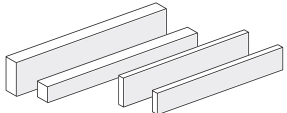
SCYON™ AXENT TRIM





| PRODUCT | DESCRIPTION | QUANTITY/SIZE |
|---|--|---|
|  | Scyon Axent Trim Material composite trim used for box corners and for trim around the windows and doors. | 38mm Scyon Trim Thickness: 38mm 38mm Width: 45mm 84mm Length: 4200mm 4200mm Approx. mass: 1.7kg/m 3.2kg/m |
| | | 16mm Scyon Trim Thickness: 16mm 16mm Width: 84mm 100mm Length: 2600mm 2600mm Approx. mass: 1.6kg/m 1.9kg/m |

PRODUCT / ACCESSORIES / TOOLS
COMPONENTS SUPPLIED BY JAMES HARDIE

| ACCESSORIES | DESCRIPTION | ACCESSORIES | DESCRIPTION |
|---|--|---|--|
|  | HardiBlade® saw blade 185mm poly diamond blade, for fast, clean cutting of Scyon Axent Trim. |  | James Hardie joint sealant Polyurethane joint sealant. |
|  | ND 50mm 304 stainless steel brad nail Pack of 2000 with fuel cell | | |

COMPONENTS NOT SUPPLIED BY JAMES HARDIE

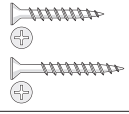
James Hardie recommends the following products for use in conjunction with its Scyon Axent Trim products. James Hardie does not supply these products and does not provide a warranty for their use. Please contact the component manufacturer for information on their warranties and further information on their products.

| ACCESSORIES | DESCRIPTION | ACCESSORIES | DESCRIPTION |
|---|--|---|--|
|  | ND 62mm 304 stainless steel brad nail |  | Wing Tip Screw For 16mm thick trim, use a 52mm class 3 wing screw by TRI-FIXX. For 38mm thick trim, use a 75mm class 3 wing screw by Powers Fasteners Australasia Pty Ltd. |
|  | Bullet head nails 3.15 x 65mm corrosion resistant bullet head nails 3.15 x 75mm corrosion resistant bullet head nails |  | Screws 8-10g x 50mm corrosion resistant chipboard/wood screws 8-10g x 65mm corrosion resistant chipboard/wood screws |
|  | Compound mitre saw Dust reducing compound mitre saw used with HardiBlade® saw blade. Makita: LS0714 / LS1013 / LS1212 Hitachi: C10FSB / C12FSB |  | Dust extraction vacuum with HEPA filter Used with HEPA filter and paper bag for reduced dust exposure. |

JAMES HARDIE RECOMMENDED SAFE WORKING PRACTICES
CUTTING OUTDOORS

1. Position cutting station so wind will blow dust away from the user or others in working area.
2. Use a dust reducing circular saw equipped with HardiBlade® saw blade and HEPA vacuum extraction.

DRILLING/OTHER MACHINING

When drilling or machining you should always wear a P1 or P2 dust mask and warn others in the immediate area.

IMPORTANT NOTES

1. NEVER use a power saw indoors.
2. NEVER use a circular saw blade that does not carry the HardiBlade® logo.
3. NEVER dry sweep - Use wet suppression or HEPA vacuum.
4. NEVER use grinders.
5. ALWAYS follow tool manufacturers' safety recommendations.

P1 or P2 respirators should be used in conjunction with above cutting practices to further reduce dust exposures. Additional exposure information is available at www.jameshardie.com.au to help you determine the most appropriate cutting method for your job requirements. If concern still exists about exposure levels or you do not comply with the above practices, you should always consult a qualified industrial hygienist or contact James Hardie for further information.

STORAGE AND HANDLING

To avoid damage, all James Hardie building products should be stored with edges and corners of the product protected from chipping. James Hardie building products must be installed in a dry state and protected from weather during transport and storage. The product must be laid flat under cover on a smooth level surface clear of the ground to avoid exposure to water, moisture, etc.

PREPARATION

Edges cut on site must be primed before installation with a coat of an oil based masonry primer paint. Slight chamfering of cut edges is recommended to improve edge paint adhesion.

Clearances

Install Scyon Axent Trim with a minimum 150mm clearance to the earth on the exterior of the building or in accordance with local building codes if greater than 150mm is required.

Maintain a minimum 50mm clearance between Scyon Axent Trim and roofs, decks, paths, steps and driveways. Adjacent finished grade must slope away from the building in accordance with local building codes, typically a minimum slope of 50mm minimum over the first metre.

Do not install Scyon Axent Trim such that it may remain in contact with standing water.

NOTE

Greater clearance may be required in order to comply with termite protection provisions.

TERMITE PROTECTION

The BCA specifies the requirements for termite barriers and must be complied with. Where the exposed slab edge is used as part of the termite barrier system, a minimum of 75mm of the exposed slab edge must be visible to permit ready detection of termite entry.

FRAMING

Scyon Axent Trim can be fixed to either timber or light gauge domestic type steel framing. The framing used must comply with the relevant building regulations and standards and the requirements of this manual. Use only seasoned timber.

Unseasoned timber must not be used, as it is prone to shrinkage and can cause Scyon Trim and frames to move. The base metal thickness of a steel frame must be between 0.55 and 1.6mm (BMT).

Fastener durability

Various grades of fastener finishes and durability are available such as galvanised, stainless steel and fasteners with proprietary coatings.

Fasteners must have the appropriate level of durability required for the intended project. This is of particular importance in coastal areas, areas subject to salt spray and other corrosive environments.

Fasteners must be fully compatible with all other materials that they are in contact with to ensure the durability and integrity of the assembly. Contact fastener manufacturers for more information.

FIXINGS

When fastening a single layer of 16mm thick Scyon Trim to timber framing use 3.15 x 65mm bullet head nails or 8 – 10g x 50mm chipboard/wood screws or ND 50mm stainless steel brad nails.

When fastening 38mm thick Scyon Trim to timber framing use 3.15 x 75mm bullet head nails or 8 – 10g x 65mm chipboard/wood screws or ND 62mm stainless steel brad nails.

NOTE

For chipboard screws pre-drill Scyon Trim beforehand using a 3mm drill bit.

0.55 - 1.2mm BMT steel framing:

For 16mm thick trim, use 52mm minimum class 3 wing screw by TRI-FIXX.

For 38mm thick trim, use 75mm minimum class 3 wing screw by Powers Fasteners Australasia Pty Ltd.

If a smooth surface appearance on the face of the trim is required, then the heads of the nails need to be finished or punched 2-3mm below the surface and filled with a water-proof exterior filling compound as per the manufacturer's recommendations. Punch below surface only suitable for bullet head and brad nails. Flat head and screws must be finished flush with the board surface.

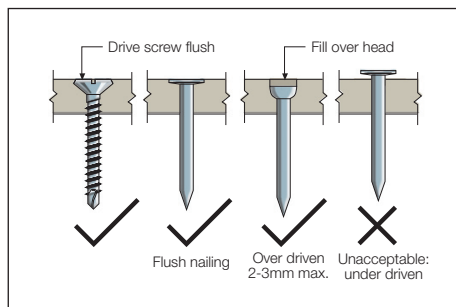

NOTE

Do not screw into the 38mm edge of the 38mm Scyon Trim, the 16mm edge of the 16mm Scyon Trim or cut Scyon Trim ends.

Flashings

Vapour permeable membranes (in accordance with AS/NZS 4200.2) and flashings must be installed behind wall and corner trims in order to drain water down and out of the wall. Refer to the appropriate external cladding technical documentation, building codes and standards for requirements. Information is also available from BRANZ regarding good flashing practices.

INSTALLATION

NOTES

- When using Scyon Trim with Scyon Linea cladding, additional framing may be required, see Scyon Linea cladding installation instructions.
- You must ensure the product is of acceptable quality prior to installation, see Important Note 3.

Scyon Trim must be fixed directly to timber framing with two fasteners at either end of the trim. Intermediate fixings are also required at 300mm maximum staggered centres. If using brad nails to fasten, intermediate fixings are required at 150mm maximum staggered centres. Intermediate fasteners are not staggered at corners where framing is off-set, see Figure 3.

When installing 38mm and 16mm Scyon Trim around windows see Figures 1 and 2 respectively.

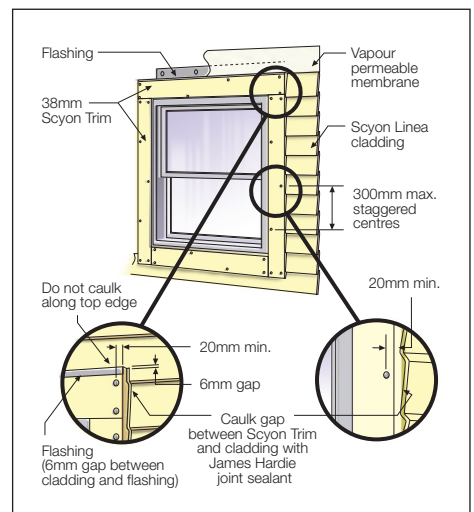

FIGURE 1 38MM SCYON AXENT TRIM FIXING AROUND WINDOW

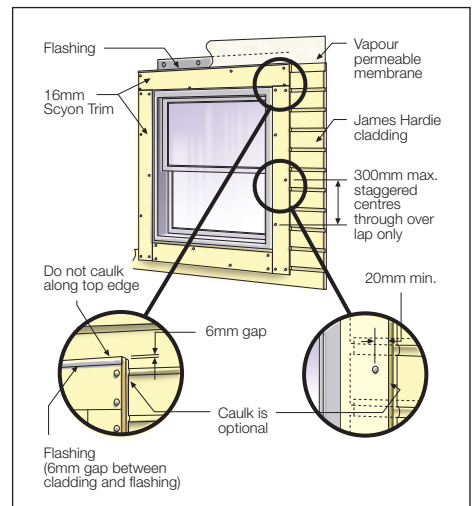

FIGURE 2 16MM SCYON AXENT TRIM FIXING AROUND WINDOW

NOTE

When nailing 16mm Scyon Trim over boards either pre-drill trim or nail through board lap.

CORNERS AND EAVES

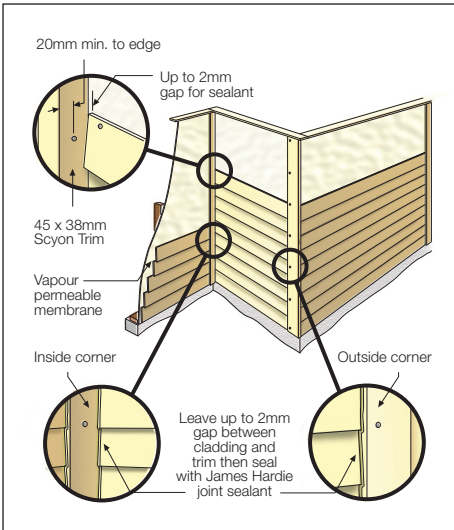

FIGURE 3 CORNER DETAIL

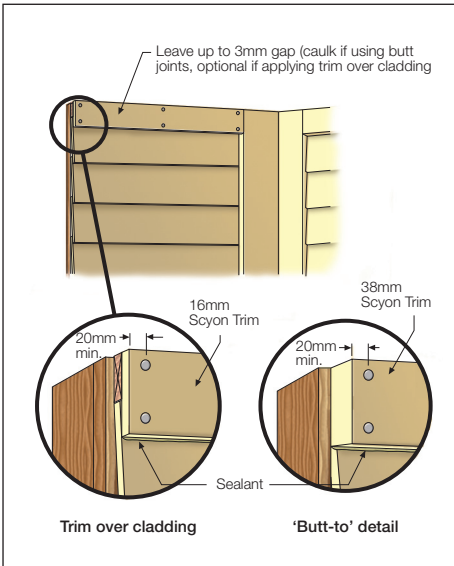

FIGURE 4 TOP OF WALL TRIM DETAILS

FINISHES

Preparation and priming

Scyon Trim is pre-primed and must be dry before painting. Where filling over fastener heads refer to page 2. Priming of filled and sanded patches may be required in accordance with paint manufacturer's specifications.

NOTE

Care must be taken not to over-sand as it can affect the finish.

Sealants

Application and use of sealants must comply with manufacturer's instructions. Sealants, if coated, must be compatible with the paint system.

Painting

Refer to the project specification for paint requirements. Scyon Trim must be painted within 3 months of being fixed. James Hardie recommends the application of two coats minimum of a quality acrylic paint over the pre-primed boards in accordance with the paint manufacturer's specifications. Some environments require special coatings. Painting selection and specifications are dependant on the paint chosen. Refer to the paint manufacturer for information and details of their warranty.

Staining

Stains containing linseed oil are specifically designed for wood and may not be suitable for James Hardie cladding products, primed or unprimed. Semi-transparent stains can vary in uniformity of appearance depending on method of application and conditions and will require a high level of skill and craftsmanship to achieve a uniform appearance. Clear coats have not proven durable in exterior exposure and James Hardie considers them a maintenance item that may require application of a refurbishing sealer at regular intervals. James Hardie does not warrant the appearance or durability of semi-transparent stains and clear coats.

MAINTENANCE

Regular cleaning and maintenance of the paint, finished surface, joints, junctions, penetrations, etc must be carried out at regular intervals to maintain finish and weather-resistance of cladding. Maintenance must also meet the requirements of the relevant component manufacturer.

PRODUCT INFORMATION

General

Scyon Trim is a reengineered concrete formulation utilising patented technology. The basic composition is Portland cement, ground sand, cellulose fibre, water and proprietary products.

Scyon Trim is manufactured to AS/NZS 2908.2 'Cellulose-Cement Products Part 2: Flat Sheets'.

Scyon Trim are classified Type A, Category 2 in accordance with AS/NZS 2908.2

For Material Safety Data Sheets (MSDS) visit www.jameshardie.com.au or Ask James Hardie™ on 13 1103.

DURABILITY

Resistance to moisture/rotting

Scyon Trim has demonstrated resistance to permanent moisture-induced deterioration (rotting) by passing the following tests in accordance with AS/NZS 2908.2:

- Water permeability (Clause 8.2.2)
- Warm water (Clause 8.2.4)
- Heat rain (Clause 6.5)
- Soak dry (Clause 8.2.5).

Resistance to fire

Scyon Trim is suitable where non-combustible materials are required in accordance with C1.12 of the Building Code of Australia.

James Hardie building products have been tested by CSIRO and are classified as Group 1 material in accordance with Specification C1.10a of the BCA.

Scyon Trim has the following early fire hazard indices (tested to AS 1530 Part 3).

| EARLY FIRE HAZARD INDICES | |
|---------------------------|-------|
| Ignition index | 0 |
| Flame spread index | 0 |
| Heat evolved index | 0 |
| Smoke developed index | 0 - 1 |

NOTES: Zero is the best possible result. The range is 0 - 10, except Ignition Index which is 0 - 20.

Resistance to termite attack

Based on testing completed by CSIRO Division of Forest Products and Ensis Australia James Hardie building products have demonstrated resistance to termite attack.

Alpine regions

In regions subject to freeze/thaw conditions, James Hardie external cladding must be painted. In addition, cladding must not be in direct contact with snow/or ice build up for extended periods, e.g. external walls in alpine regions subject to snow drifts over winter.

Tested to AS/NZS 2908.2 Clause 8.2.3

WARRANTY

James Hardie Australia Pty Limited ("James Hardie") warrants to the first purchaser of the product and the last purchaser prior to installation of the product for a period of 10 years from the date of purchase that the Scyon™ Trim (the "Product"), will be free from defects due to defective factory workmanship or materials and, subject to compliance with the conditions below, will be resistant to cracking, rotting, fire and damage from termite attacks to the extent set out in James Hardie's relevant published literature current at the time of installation. James Hardie warrants for a period of 12 months from the date of purchase that the accessories supplied by James Hardie will be free from defects due to defective factory workmanship or materials.

Nothing in this document shall exclude or modify any legal rights a customer may have under the Trade Practices Act or otherwise which cannot be excluded or modified at law.

Conditions of warranty

The warranty is strictly subject to the following conditions:

- a) James Hardie will not be liable for breach of warranty unless the claimant provides proof of purchase and makes a written claim either within 30 days after the defect would have become reasonably apparent or, if the defect was reasonably apparent prior to installation, then the claim must be made prior to installation;
- b) this warranty is not transferable;
- c) the Product must be installed and maintained strictly in accordance with the relevant James Hardie literature current at the time of installation and must be installed in conjunction with the components or products specified in the literature. To obtain copies of such literature contact Ask James Hardie™ on 13 11 03. Further, all other products, including coating and jointing systems, applied to or used in conjunction with the Product must be applied or installed and maintained strictly in accordance with the relevant manufacturer's instructions and good trade practice;
- d) the project must be designed and constructed in strict compliance with all relevant provisions of the current Building Code of Australia, regulations and standards;
- e) the claimant's sole remedy for breach of warranty is (at James Hardie's option) that James Hardie will either supply replacement product, rectify the affected product or pay for the cost of the replacement or rectification of the affected product;

- f) James Hardie will not be liable for any losses or damages (whether direct or indirect) including property damage or personal injury, consequential loss, economic loss or loss of profits, arising in contract or negligence or howsoever arising.

Without limiting the foregoing James Hardie will not be liable for any claims, damages or defects arising from or in any way attributable to poor workmanship, poor design or detailing, settlement or structural movement and/or movement of materials to which the Product is attached, incorrect design of the structure, acts of God including but not limited to earthquakes, cyclones, floods or other severe weather conditions or unusual climatic conditions, efflorescence or performance of paint/coatings applied to the Product, normal wear and tear, growth of mould, mildew, fungi, bacteria, or any organism on any Product surface or Product (whether on the exposed or unexposed surfaces);

- g) all warranties, conditions, liabilities and obligations other than those specified in this warranty are excluded to the fullest extent allowed by law;
- h) if meeting a claim under this warranty involves re-coating of Products, there may be slight colour differences between the original and replacement Products due to the effects of weathering and variations in materials over time.

DISCLAIMER

The recommendations in James Hardie's literature are based on good building practice, but are not an exhaustive statement of all relevant information and are subject to conditions (c), (d), (f) and (g) above. Further, as the successful performance of the relevant system depends on numerous factors outside the control of James Hardie (eg quality of workmanship and design) James Hardie shall not be liable for the recommendations in that literature and the performance of the relevant system, including its suitability for any purpose or ability to satisfy the relevant provisions of the Building Code of Australia, regulations and standards.

For more information please Ask James Hardie™ on 13 11 03 or visit www.jameshardie.com.au

Ask James Hardie™
Call 13 11 03
www.jameshardie.com.au

COPYRIGHT AUGUST 2008
© JAMES HARDIE AUSTRALIA PTY LTD ABN 12 084 635 558
™ AND ® DENOTES A TRADEMARK OR REGISTERED MARK
OWNED BY JAMES HARDIE INTERNATIONAL FINANCE BV.