

Installation Instructions

IMPORTANT NOTES

1. Failure to install, finish or maintain this product in accordance with applicable building codes, regulations, standards and James Hardie's written application instructions may lead to personal injury, affect system performance, violate local building codes, and void James Hardie's product warranty.
2. All warranties, conditions, liabilities (direct, indirect or consequential) and obligations whether arising in contract, tort or otherwise other than those specified in James Hardie's product warranty are excluded to the fullest extent allowed by law. For James Hardie's product warranty information and disclaimers about the information in this manual, see the section at the end of this manual.
3. The builder must ensure the product meets aesthetic requirements before installation. James Hardie will not be responsible for rectifying aesthetic surface variations following installation.
4. Make sure your information is up to date. When specifying or installing James Hardie® products, ensure you have the current manual. If in doubt, or you need more information, visit www.jameshardie.com.au or Ask James Hardie™ on 13 11 03.

WARNING
DO NOT BREATHE DUST AND CUT ONLY IN WELL VENTILATED AREA

James Hardie products contain sand, a source of respirable crystalline silica which is considered by some international authorities to be a cause of cancer from some occupational sources. Breathing excessive amounts of respirable silica dust can also cause a disabling and potentially fatal lung disease called silicosis, and has been linked with other diseases. Some studies suggest smoking may increase these risks. During installation or handling:

- (1) work in outdoor areas with ample ventilation;
- (2) minimise dust when cutting by using either 'score and snap' knife, fibre cement shears or, where not feasible, use a HardiBlade® saw blade and dust reducing circular saw attached to a HEPA vacuum;
- (3) warn others in the immediate area to avoid breathing dust;
- (4) wear a properly-fitted, approved dust mask or respirator (e.g. P1 or P2) in accordance with applicable government regulations and manufacturer instructions to further limit respirable silica exposures. During clean-up, use HEPA vacuums or wet cleanup methods - never dry sweep. For further information, refer to our installation instructions and Material Safety Data Sheets available at www.jameshardie.com.au. FAILURE TO ADHERE TO OUR WARNINGS, MATERIAL SAFETY DATA SHEETS, AND INSTALLATION INSTRUCTIONS MAY LEAD TO SERIOUS PERSONAL INJURY OR DEATH.

JAMES HARDIE RECOMMENDED SAFE WORKING PRACTICES
CUTTING OUTDOORS

1. Position cutting station so wind will blow dust away from the user or others in working area.
2. Use one of the following methods based on the required cutting rate:
 - Better** ■ Dust reducing circular saw equipped with HardiBlade® Saw blade and HEPA vacuum extraction.
 - Good** ■ Dust reducing circular saw equipped with HardiBlade® saw blade.

CUTTING INDOORS

- Cut only using score and snap, hand guillotine or fibreshaers (manual, electric or pneumatic).
- Position cutting station in a well-ventilated area.

DRILLING/OTHER MACHINING

When drilling or machining you should always wear a P1 or P2 dust mask and warn others in the immediate area.

IMPORTANT NOTES

1. For maximum protection (lowest respirable dust production), James Hardie recommends always using "Best" - level cutting methods where feasible.
2. NEVER use a power saw indoors.
3. NEVER use a circular saw blade that does not carry the HardiBlade® logo.
4. NEVER dry sweep - Use wet suppression or HEPA vacuum.
5. NEVER use grinders.
6. ALWAYS follow tool manufacturers' safety recommendations.

P1 or P2 respirators should be used in conjunction with above cutting practices to further reduce dust exposures. Additional exposure information is available at www.jameshardie.com.au to help you determine the most appropriate cutting method for your job requirements. If concern still exists about exposure levels or you do not comply with the above practices, you should always consult a qualified industrial hygienist or contact James Hardie for further information.

STORAGE AND HANDLING

To avoid damage, all James Hardie building products should be stored with edges and corners of the product protected from chipping. James Hardie building products must be installed in a dry state and protected from weather during transport and storage. The product must be laid flat under cover on a smooth level surface clear of the ground to avoid exposure to water, moisture, etc.

MATRIX™ SHEET AND SCYON™ CAVITY TRIM PRODUCT SIZE

PRODUCT	LENGTH (mm)	WIDTH (mm)	THICKNESS (mm)	MASS (kg)
MATRIX SHEET 	1190	1190	8	18
	2390	590	8	18
	1790	890	8	20
	2990	1190	8	45
SCYON CAVITY TRIM 	2450	70	19	3.4

All dimensions and masses provided are approximate only and subject to manufacturing tolerances. Masses are based on equilibrium moisture content of product.

ACCESSORIES / TOOLS SUPPLIED BY JAMES HARDIE

ACCESSORIES	DESCRIPTION	ACCESSORIES	DESCRIPTION
	JH backing strip 0.55mm BMT black high-tensile roll formed steel with pre-formed stop for creating horizontal expressed panel joints. Pack of 10 1190, 2390 and 2990mm lengths		JH facade washer Opaque nylon 6 washer fits beneath the appropriate exposed head fasteners when using pre-finished panels. JH facade washers are recommended to be inserted between the panel and the exposed head fastener. Pack of 1000
	James Hardie base coat Water resistant jointing compound. Used to flush finish over epoxy when countersinking fasteners.		C25 stainless steel brad nails C25 16 gauge 304 stainless steel brad nails used with James Hardie joint sealant for fixing Matrix panels to the Scyon cavity trim. Pack of 2000 includes fuel cell.
	James Hardie joint sealant Paintable polyurethane sealant Pack of 20 300 mL cartridge		JH 18mm PVC cavity vent strip Used at the bottom of walls behind the Matrix panel. 3000mm long / Pack of 10
TOOLS			
	HardiBlade® saw blade Diamond tip 185mm diameter circular saw blade for fast, clean cutting of Matrix panels and Scyon cavity trim. Selling unit: Each		40mm HardiDrive® screw For fastening Scyon cavity trim to 0.8 to 1.6mm BMT steel stud frames.

COMPONENTS NOT SUPPLIED BY JAMES HARDIE

James Hardie recommends the following products for use in conjunction with its Scyon™ Matrix™ cladding. James Hardie does not supply these products and does not provide a warranty for their use. Please contact the component manufacturer for information on their warranties and further information on their products.

ACCESSORIES	DESCRIPTION	ACCESSORIES	DESCRIPTION
	Vapour permeable membrane Must have the following properties in accordance with AS/NZS 4200.1: fixing to timber framing. Vapour barrier - low or medium. Water barrier - high		Epoxy flush sealing (2 part) Countersunk head screws are flush sealed using mexapoxy P1 or Hilti CA 125. Where the temperature is below 15° use Hilti CA 273.
	Gun Nail Trim To Frame 2.8mm x 65mm long nail or 75 x 2.8mm D or round head galvanised smooth shank nail used to fix Scyon cavity trim to timber stud. Min. Class 3		Countersunk screws 8-10 x 25 Class 3 galvanised countersunk needle point screw.
	Nails To Fix Panel To Cavity Trim 2.8 x 30mm galvanised nail, 2.6 x 32mm galvanised or stainless steel twist shank nail. Nail head must be a minimum round head diameter of 5.3mm, 25mm DA stainless steel Brad Nail for fixing Matrix panels to Scyon cavity trim.		6mm masonry drill and countersunk head drill Drill bit provides a 6.2mm to 6.3mm diameter hole. Used to pre-drill clearance holes for screw fasteners. The countersunk head drill is used to countersink fasteners.
	Exposed head fasteners No. 8-15 x 25mm wafer or hex head needle point screw. Class 3 minimum coating.		Nail gun Suitable for use with the C25 304 stainless steel brad nails.
	3M HIPA 300 adhesive cleaner For cleaning of surfaces prior to applying double sided tape to the JH backing strip. Supplied by 3M Australia Pty Ltd. Part no. AS010418940		Double sided tape Alternate method to fix the lower part of the JH backing strip to the back of the Matrix panel at horizontal joints. Henkel C3 12mm or 3M 12.7mm wide 4905VHB double sided tape may be used.
	Dust-reducing saw Dust reducing saw with a HardiBlade® saw blade. Makita 5057KB / Hitachi C7YA		Vacuum extraction with HEPA filter Used with HEPA filter and paper bag for reduced dust exposure.

INTRODUCTION AND SCOPE

General

Scyon™ Matrix™ cladding consists of Scyon cavity trim installed over vapour permeable membrane to which the pre-sealed Matrix panels are fixed. Expressed vertical and horizontal joints are created to produce a panelised look.

This manual covers the use of the Scyon Matrix cladding in a residential facade application over a seasoned timber or a light-gauge steel frame. Scyon Matrix cladding is not suitable for sloping walls or on a diagonal orientation.

DESIGN

General

All design and construction must comply with the appropriate requirements of the current Building Code of Australia (BCA) and other applicable regulations and standards.

Responsibility

The specifier or other party responsible for the project must ensure that the details in this specification are appropriate for the intended application and that additional detailing is performed for specific design or any areas that fall outside the scope of this specification.

Slab and footings

The slab and footings on which the building is situated must comply with AS 2870 'Residential slabs and footings – Construction' and the requirements of the Building Code of Australia (BCA).

Ground clearances

Install James Hardie external cladding with a minimum 150mm clearance to the earth on the exterior of the building or in accordance with local building codes if greater than 150mm is required.

Maintain a minimum 50mm clearance between James Hardie external cladding and roofs, decks, paths, steps and driveways.

Adjacent finished grade must slope away from the building in accordance with local building codes, typically a minimum slope of 50mm minimum over the first metre.

Do not install external cladding such that it may remain in contact with standing water.

NOTE

Greater clearance may be required in order to comply with termite protection provisions, see below for more information.

Termite Protection

The BCA specifies the requirements for termite barriers. Where the exposed slab edge is used as part of the termite barrier system, a minimum of 75mm of the exposed slab edge must be visible to permit ready detection of termite entry.

MOISTURE MANAGEMENT

General

It is the responsibility of designer or specifier to identify moisture related risks associated with any particular building design. Wall construction design must effectively manage moisture, accounting for both the interior and exterior environments of the building, particularly in buildings that have a higher risk of wind driven rain penetration or that are artificially heated or cooled.

In addition all wall openings, penetrations, junctions, connections, window sills, heads and jambs must incorporate appropriate flashing and waterproofing. Materials, components and their installation that are used to manage moisture in framed wall construction must, at a minimum, comply with the requirements of relevant standards and the BCA.

Vapour permeable membrane

A vapour permeable membrane must be installed under the Scyon™ cavity trim in accordance with the AS/NZS 4200.2 'Pliable building membranes and underlays – Installation' and the manufacturer's specifications.

The membrane must have the following properties in accordance with AS/NZS 4200.1:

- Vapour barrier - low or medium
- Water barrier - high

The function of the vapour permeable membrane is to prevent moisture ingress by acting as a "drainage plane" whilst enabling water vapour build up from inside the frame to escape.

Flashing

All wall openings, penetrations, intersections, connections, window sills, heads and jambs must be flashed prior to cladding installation.

FRAMING

General

Frame set-out and construction is an important aspect to consider when planning the installation of Scyon Matrix cladding. The way you install the panels will affect the way you build the frame. Matrix panels and Scyon cavity trim are installed either on or off stud, refer to Figures 4 and 5.

When installing on stud, the vertical panel joints are located centrally over the Scyon cavity trim. For this method of installation it is important that the stud set-out accurately matches the vertical joint locations.

Alternatively, for the off-stud installation method, noggings must be installed at 800mm maximum centres, see Figure 5. The noggings must be aligned with the exterior plane of the frame to ensure that a flush surface is provided to accommodate the installation of the Scyon cavity trim. Off stud fixing is not suitable in high wind loads, see Table 1. This table specifies the maximum stud spacings for Scyon Matrix cladding for Australian wind load classifications of AS 4055 'Wind Loads for Housing'.

Timber

Use of timber framing must be in accordance with AS 1684 - 'Residential timber-framed construction' and the framing manufacturer's specifications.

Use only seasoned timber. Unseasoned timber must not be used because it is prone to shrinkage and can cause sheets and frames to move.

'Timber used for house construction must have the level of durability appropriate for the relevant climate and expected service life and conditions including exposure to insect attacks or to moisture, which could cause decay.'

Reference AS 1684.2' Residential timber-framed construction'.

Stud framing members must be a minimum of 70x35mm,

Steel

Use of steel framing must be in accordance with AS 3623 - 'Domestic metal framing' and the framing manufacturers specifications.

Framing members must have a Base Metal Thickness (BMT) between 0.55 to 1.6mm. The steel framing must have the appropriate level of durability required to prevent corrosion. Stud framing members must be a minimum of 64x35mm.

Tolerances

Ensure frame is square and work from a central datum line. Frames must be straight and true to provide a flush face to receive the panels.

A suggested maximum tolerance of between 3mm and 4mm in any 3000mm length of frame will give best results, see Figure 1. Scyon Matrix cladding will not straighten excessively warped or distorted frames and any warping may still be visible after the cladding is applied.



FIGURE 1 FRAME STRAIGHTNESS

FASTENERS

General

Suitable type of fasteners and spacings are provided on the following pages for both the Scyon cavity trim and Matrix panels.

All fasteners specified should be driven flush as shown in Figure 2.

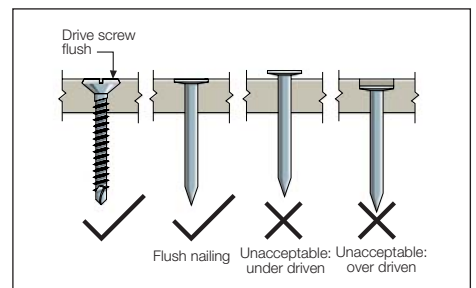

FIGURE 2 NAIL FASTENER DEPTH

Screw fasteners should be screwed as close as possible to the stud corners to avoid deflection of the stud flange.

Fastener durability

Fasteners must have the appropriate level of durability required for the intended project. This is of particular importance in coastal areas, areas subject to salt spray and other corrosive environments. Fasteners must be fully compatible with all other materials that they are in contact with to ensure the durability and integrity of the assembly. Contact fastener manufacturers for more information.

PREPARATION

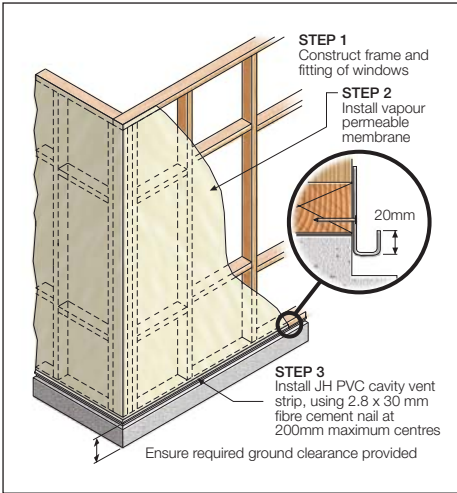

FIGURE 3 PREPARATION

NOTE

Generally, external and internal corners have additional framing requirements. Refer to the external and internal corner details for more information.

SCYON CAVITY TRIM INSTALLATION

General

The Scyon cavity trim is installed vertically over the vapour permeable membrane to either timber or metal stud wall frames. The Scyon cavity trim may be installed either on or off stud, refer to framing section for more information and Figures 4 and 5.

On-stud fixing

For on-stud fixing the Scyon cavity trim is installed directly to stud over the vapour permeable membrane, see Figure 4. For fastener and stud spacings, refer to Table 1.

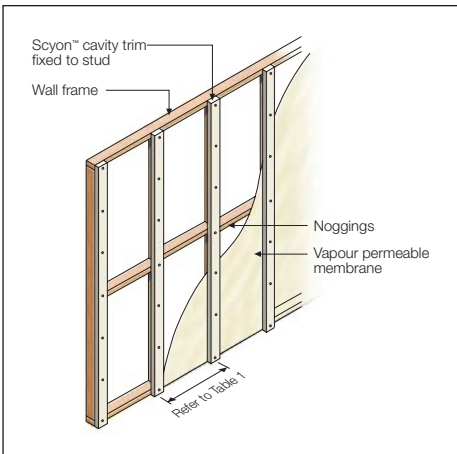

FIGURE 4 ON-STUD FIXING

Off-stud fixing

The Scyon cavity trim can be installed off-stud over the vapour permeable membrane. It is important that horizontal supports (noggings) are installed at a maximum of 800mm vertical centres. A specified fastener is fixed at the intersection of every support, see Figure 5. For Scyon cavity trim and stud spacings, refer to Table 1.

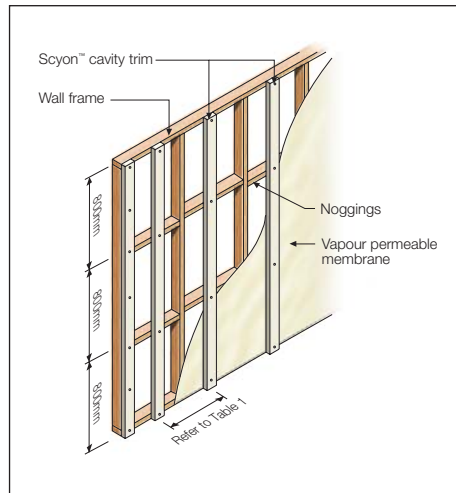

FIGURE 5 OFF-STUD FIXING

Layout

Planning the layout of the Scyon cavity trim and the Matrix panels is an essential part of installation to ensure a professional finish.

Datum lines should be set-up and used to ensure the edges of the Scyon cavity trim and Matrix panels are square. Datum lines can include the edges of windows, doors and building corners, see Figure 6.

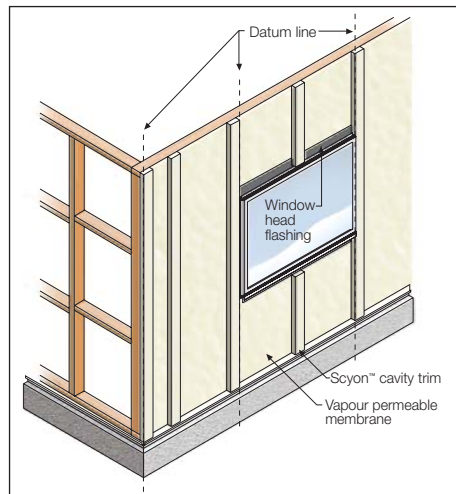

FIGURE 6 PANEL LAYOUT



FIGURE 7 PLUMB SCYON CAVITY TRIM

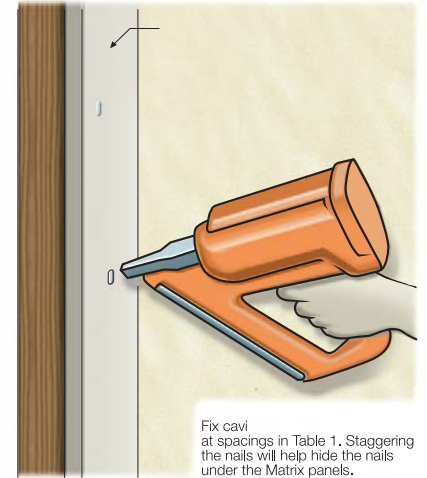

FIGURE 8 FIXING SCYON CAVITY TRIM

Ensure the Scyon cavity trim butts up to the JH PVC vent strip. Do not insert the Scyon cavity trim into the JH PVC vent strip.

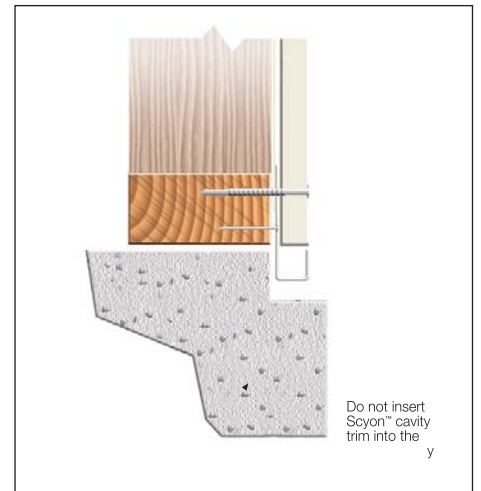

FIGURE 9 SLAB EDGE DETAIL

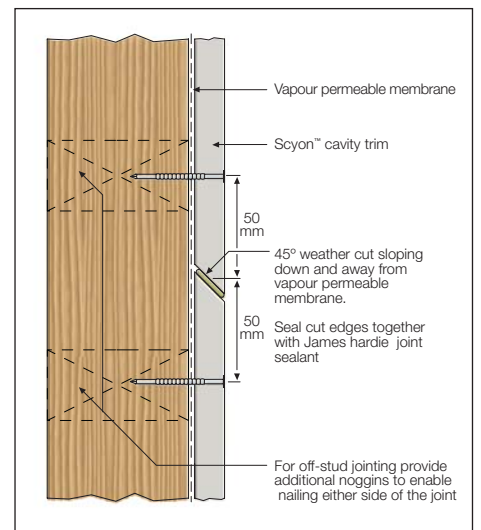

FIGURE 10 SCYON CAVITY TRIM BUTT DETAIL

Scyon Cavity trim fasteners

For timber frames, use a corrosion resistant 65 x 2.8mm ring shank nail or a 75 x 2.8mm D or round head galvanised smooth shank nail.

For steel frames 0.55 – 0.75mm BMT, use a Buildex FibreZIPS® 30mm long screw.

For steel frames 0.8 – 1.6mm BMT, use a 40mm long HardiDrive® screw.

NOTE: Do not fasten within 30mm of the Scyon cavity trim ends and within 20mm of the edges.

TABLE 1

SCYON MATRIX CLADDING DESIGN TABLE					
AS 4055 Wind classification		Can Scyon cavity trim be fixed off-stud	Stud & Scyon cavity trim spacing (mm)	Scyon* cavity trim fastener spacing (mm)	Matrix panel fastener spacing (mm)
Non-cyclonic	Cyclonic				
ALL SPECIFIED FASTENERS EXCEPT BRAD NAILS					
N1, N2, N3	C1	YES	600	300	200
N4	C2	NO	600	200	200
N5	C3	NO	400	200	200
N6	C4	NO	400	200	150
BRAD NAILS ONLY					
N1, N2		YES	600	300	200
N3	C1	YES	600	300	150**
N4	C2	NO	N/A	N/A	N/A
N5	C3	NO	N/A	N/A	N/A
N6	C4	NO	N/A	N/A	N/A

* In the case of fixing the cavity trim off stud, the fastener spacing will be at each support i.e. a maximum of 800mm centres, see Figure 5.

**If the C25 SS Brad nail is used, the spacing may be increased to 200mm.

JH BACKING STRIP INSTALLATION

General

At horizontal panel joints, the JH backing strip is bonded to the back of the Matrix panels to form a socket to which the next course of panels are fixed over. The lower side of the JH backing strip can be bonded using either James Hardie joint sealant or double sided backing tape, see Figures 11 and 12.

Ensure all surfaces are free of dust and grime.

Joint sealant option

This method involves applying a continuous bead of James Hardie joint sealant to the lower flange of the JH backing strip, see Figure 11.

NOTE:

The sealant applied to the backing strip below the stop must be fully cured before the panel is installed.

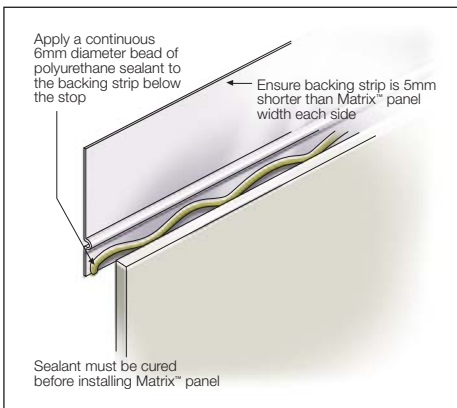

FIGURE 11 JOINT SEALANT OPTION 1

Double sided backing tape option

This method involves applying a continuous strip of 3M 12.7mm wide 4905VHB or Henkel C3 12mm double sided tape to the lower side of the JH backing strip, see Figure 12.

James Hardie recommends the surfaces are cleaned with the 3M HIPA clean 300 adhesive cleaner, in accordance with the manufacturer's recommendations.

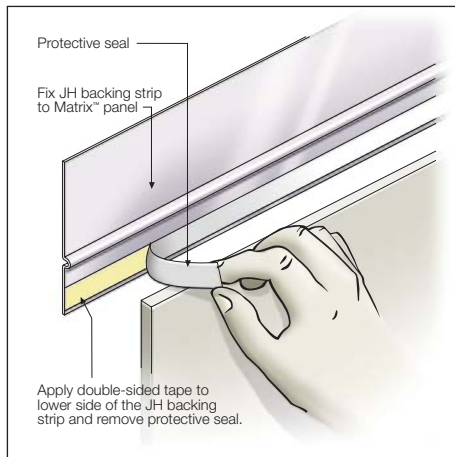

FIGURE 12 DOUBLE SIDED BACKING TAPE OPTION 2

When the panels are ready to be installed, apply James Hardie joint sealant behind the JH backing strip and a continuous filler of JH joint sealant along the top edges of the panel, see Figure 13. This detail is applicable for both the sealant and double sided backing tape options.

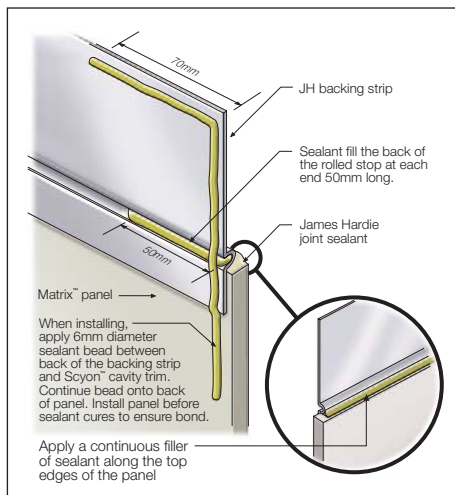

FIGURE 13 SEALING JH BACKING STRIP END DETAIL

MATRIX PANEL INSTALLATION

Note: You must ensure the product is of acceptable quality prior to installation, see Important Note 3.

General

The Matrix panels must be fixed to the Scyon cavity trim. The Matrix panels can be installed in a horizontal or vertical orientation.

The panels are installed with a 10mm expressed joint between adjacent panels, vertically and horizontally.

When installing the Matrix panels, the clear surface of the Matrix panel faces the frame.

In order to seal cut edges or sanded patches, two coats of an appropriate primer should be applied at the time of cutting or sanding compatible with finish coating eg. Watty's Kill Rust Heavy Duty Primer, Dulux AcraPrime 501/1 (water based) or equivalent.

The following installation steps outline the fixing of the Matrix panels to the Scyon cavity trim. Also refer to Figures 19-22 for further information.

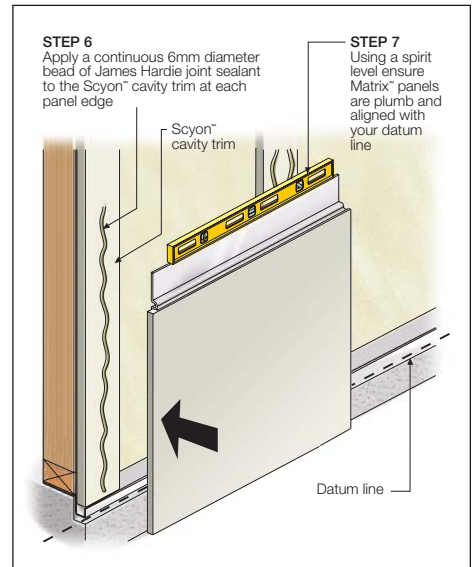

FIGURE 14 INSTALL FIRST PANEL

Figure 15 outlines the fastener spacings into the Matrix panel.

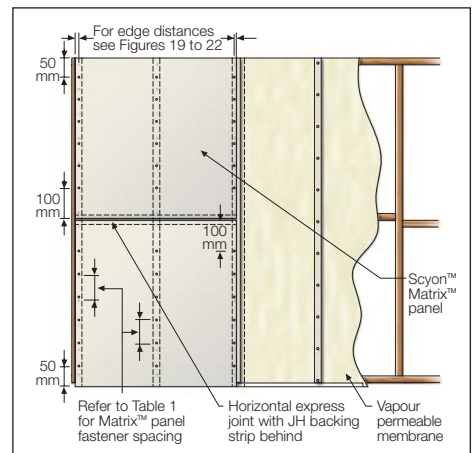

FIGURE 15 MATRIX PANEL FASTENERS

Matrix panel fasteners

The following fixing options are used to fix the Matrix panels to the Scyon cavity trim (also see Figures 19-22):

1. C25mm 16 gauge or 25 DA 304 stainless steel brad nails.
2. 2.8x30mm corrosion resistant fibre cement nails, 2.6 x 32mm galvanised or stainless steel twist shank nail with a minimum round head diameter of 5.3mm.
3. 25mm countersunk needle point stainless steel screw.
4. 25mm wafer or pan head stainless steel needle point screws.

NOTE: When using brad nails ensure that brad nails are not used in high wind areas, see Table 1.

In all options, a continuous bead of James Hardie joint sealant is applied to the Scyon cavity trim to fix the back of the Matrix panel to the Scyon cavity trim, see Figure 16.

For screw fasteners, a clearance hole must be created using a 6mm masonry drill. For countersunk screws, the fastener must also be countersunk 2.5 to 3mm below the Matrix panel's surface, see Figure 21. The countersunk fastener is then flushed finished with epoxy and then with James Hardie base coat. Use only proven epoxies for this application, i.e. Megapoxy P1 or Hilti CA 125. Where the temperature is below 15°, use Hilti CA 273. For exposed head screws a JH facade washer is recommended to be inserted between the panel and the exposed head fastener, see Figure 22.

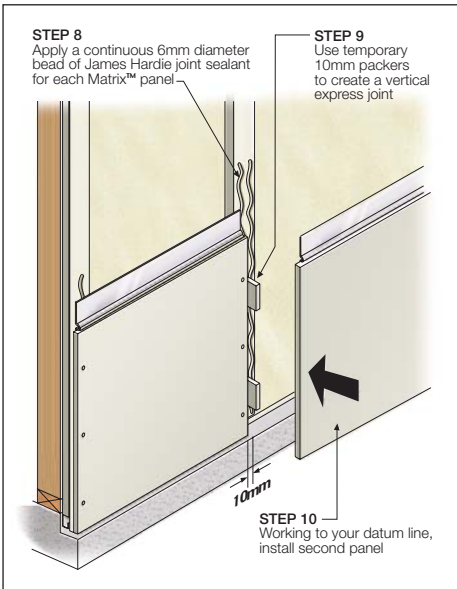

FIGURE 16 INSTALL ADJACENT PANEL

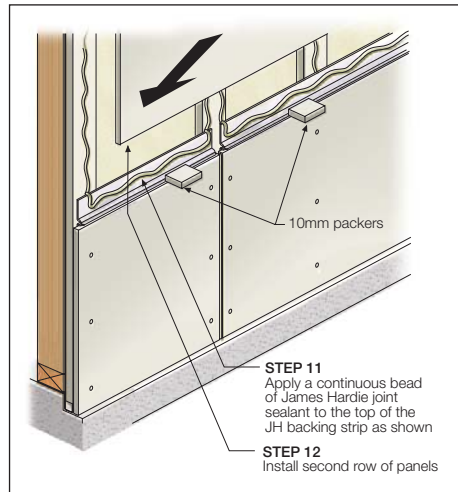

FIGURE 17 INSTALL NEXT COURSE OF PANELS

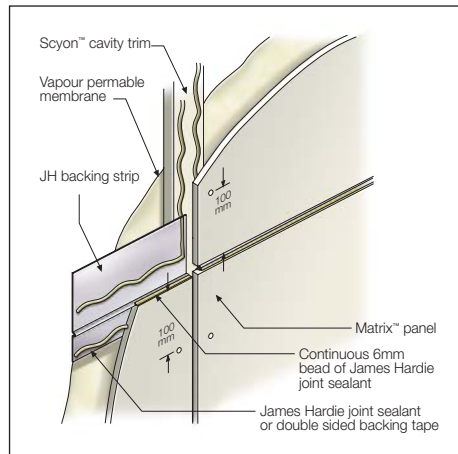

FIGURE 18 JOINT SEALANT PREPARATION

FASTENER FIXING OPTIONS

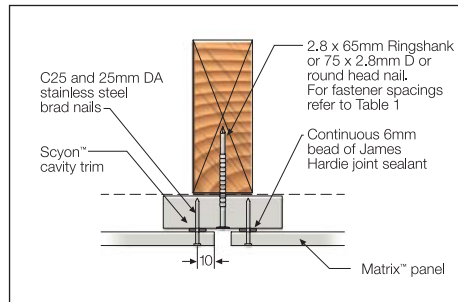

FIGURE 19 BRAD NAIL OPTION 1

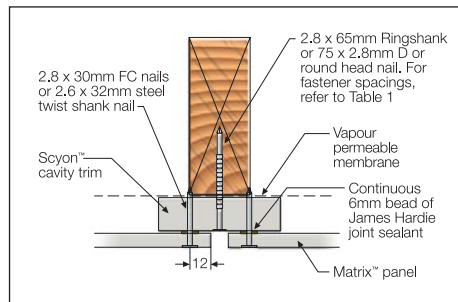

FIGURE 20 STANDARD NAIL OPTION 2

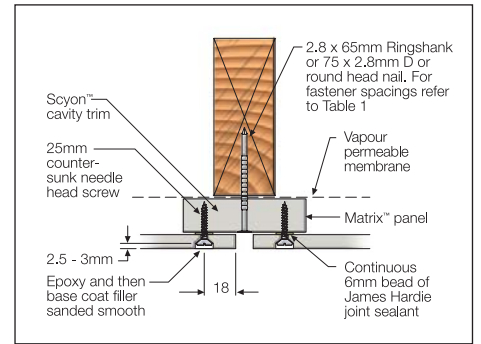

FIGURE 21 COUNTERSUNK SCREW OPTION 3

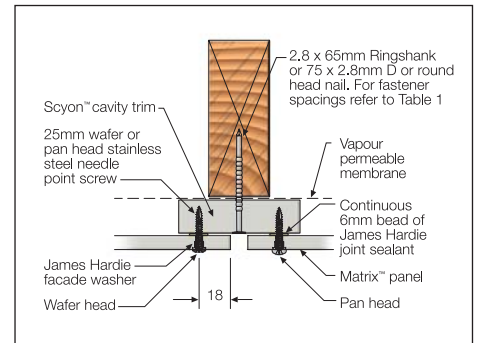

FIGURE 22 EXPOSED HEAD OPTION 4

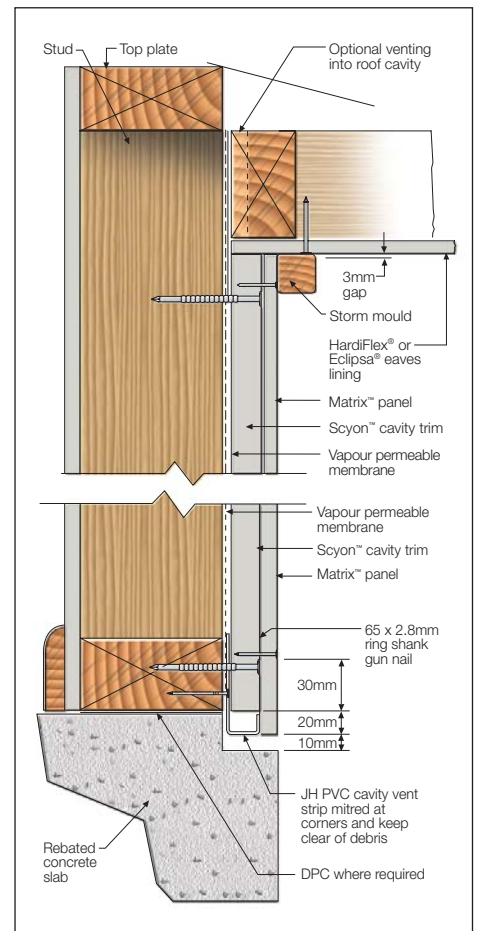

FIGURE 23 SLAB/EAVES DETAIL

WINDOWS/PARAPETS

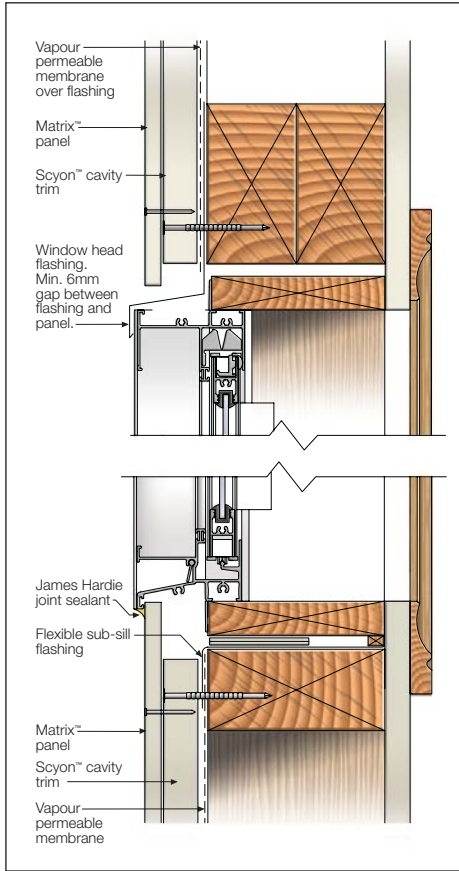

FIGURE 24 WINDOW HEAD/SILL DETAIL

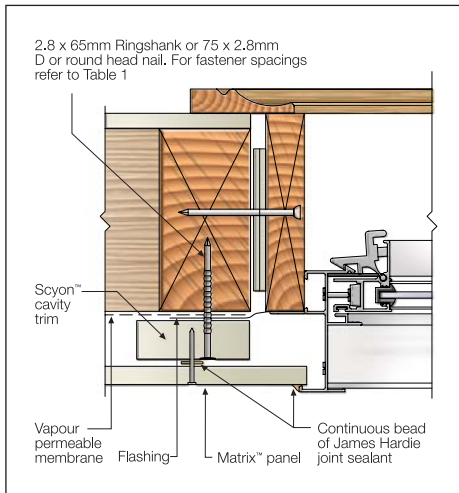

FIGURE 25 WINDOW JAMB DETAIL

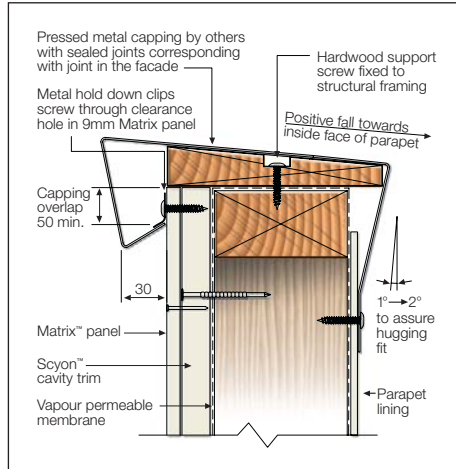

FIGURE 26 PARAPET CAPPING DETAIL

EXTERNAL CORNER DETAILS

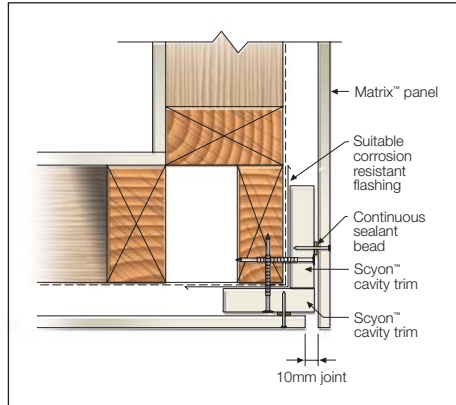

FIGURE 27 EXTERNAL CORNER DETAIL

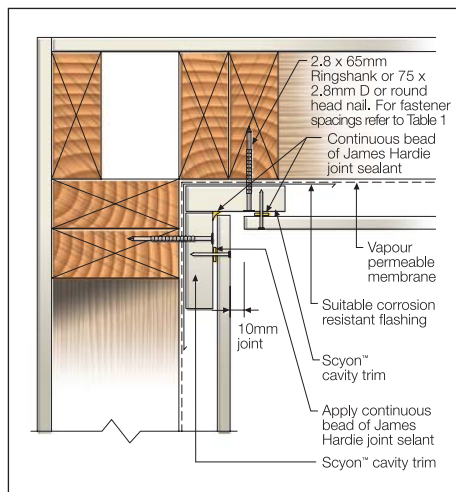

FIGURE 28 INTERNAL CORNER DETAIL

JUNCTION DETAILS

When using solid floor joists, Scyon cavity trim must not run continuously from lower floor to upper floor level. There must be a vertical 15mm gap between the Scyon cavity trim at the floor level junction to allow for timber movement, refer to Figure 29.

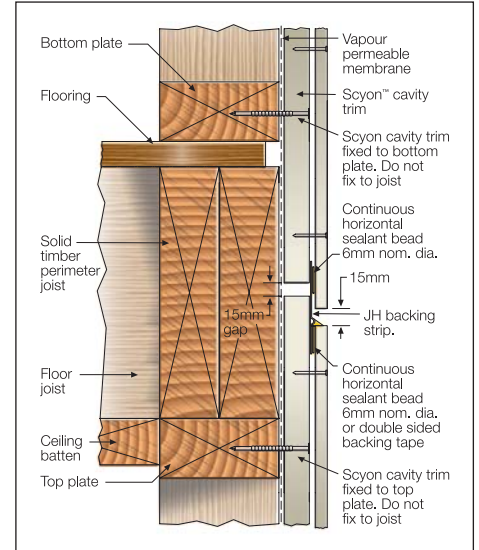

FIGURE 29 FLOOR LEVEL JUNCTION

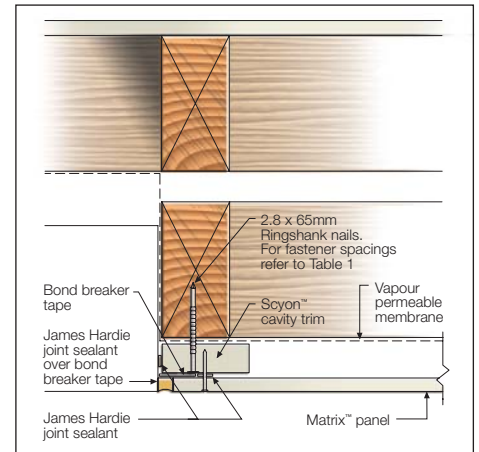

FIGURE 30 ABUTMENT DETAIL

NOTES

- To cover the 15mm gap in the Scyon cavity trim at the vertical expressed joint, use a section of JH backing strip over joint and adequately seal it in place to prevent moisture entry.
- Where solid joists are not used, consideration should be given to allow for shrinkage movement across joint. One option is to leave a 5mm sealed gap between Scyon cavity trim.

FIRE RATED WALLS

Scyon Matrix clad walls can achieve fire ratings of 60/60/60 and 90/90/90 when constructed with additional fire rated linings as specified in the James Hardie fire and acoustically rated walls design manual and construction of fire and acoustically rated walls technical specification.

Furthermore, as the Scyon Matrix cladding consists of Scyon cavity trim installed over the wall frame, the fire and water resistant plasterboard must be installed behind the vapour permeable membrane and Scyon cavity trim. It must not be directly installed behind the Matrix panels. The length of the fasteners fixing the Scyon cavity trim to the wall frame will need to take into account the thickness of the fire and water resistant plasterboard.

FINISHES

General

Refer to the project specification for paint requirements. Matrix cladding and exposed Scyon cavity trim must be painted within 3 months of being fixed.

The rear of the Matrix panel must not be left permanently exposed to direct sunlight.

In order to seal cut edges or sanded patches two coats of an appropriate primer should be applied at the time of cutting or sanding compatible with finish coating e.g. Dulux AcraPrime 501/1 (water based).

James Hardie recommends the application of two coats minimum of a quality acrylic paint over the pre-primed Matrix panels and the exposed Scyon cavity trim in accordance with the paint manufacturer's specifications. Painting selection and specifications is dependant on the paint chosen. Gloss paints are not recommended.

Coastal areas

In areas within 1km of a coastal area or corrosive environment, the Matrix panels must be painted immediately after fixing sheets, to minimise build up of contamination on the heads of the fasteners, as it may lead to fastener corrosion. Also refer to maintenance requirements and fastener section for more information.

Refer to the paint and fastener manufacturer for further information, suitable products and details of their warranty.

Sealant

Application and use of sealants must comply with manufacturer's instructions. Sealants, if coated, must be compatible with the paint system.

STAINING

Stains containing linseed oil are specifically designed for wood and may not be suitable for James Hardie cladding products, primed or un-primed.

Semi-transparent stains can vary in uniformity of appearance depending on method of application and conditions and will require a high level of skill and craftsmanship to achieve a uniform appearance. Clear coats have not proven durable in exterior exposure and James Hardie considers them a maintenance item that may require application of a refurbishing sealer at regular intervals. James Hardie does not warrant the appearance or durability of semi-transparent stains and clear coats.

MAINTENANCE

The extent and nature of maintenance will depend on the geographical location and exposure of the building. As a guide, it is recommended that basic normal maintenance tasks shall include but not be limited to:

- Washing down exterior surfaces every 6-12 months*
- Periodic inspections should be made to ensure fasteners are adequately securing the panels to framing.
- Re-applying of exterior protective finishes*
- Maintaining the exterior envelope and connections including joints, penetrations, flashings and sealants that may provide a means of moisture entry beyond the exterior cladding.
- Cleaning out gutters, blocked pipes and overflows as required.
- Pruning back vegetation that is close to or touching the building.

*Refer to your paint manufacturer for washing down and recoating requirements related to paint performance.

PRODUCT INFORMATION

Material

The basic composition of Matrix panels and Scyon cavity trim is Portland cement, ground sand, cellulose fibre, water and proprietary additives.

James Hardie building products are manufactured to Australian/New Zealand Standard AS/NZS 2908.2 'Cellulose-Cement Products-Flat Sheet'.

Matrix panels and Scyon cavity trim are classified Type A, Category 3 in accordance with AS/NZS 2908.2

Durability

Resistance to moisture/rotting

Matrix panels and Scyon cavity trim have demonstrated resistance to permanent moisture induced deterioration (rotting) by passing the following tests in accordance with AS/NZS 2908.2:

- Water permeability (Clause 8.2.2)
- Warm water (Clause 8.2.4)
- Heat rain (Clause 6.5)
- Soak dry (Clause 8.2.5)

Resistance to termite attack

Based on testing completed by CSIRO Division of Forest Products and Ensis Australia James Hardie building products have demonstrated resistance to termite attack.

Resistance to Fire

James Hardie building products are suitable where non-combustible materials are required in accordance with C1.12 of the Building Code of Australia.

James Hardie building products have been tested by CSIRO and is classified as a Group 1 material in accordance with Specification C1.10a of the BCA.

Matrix panels and Scyon Trim have the following early fire hazard Indices (tested to AS 1530 Part 3).

EARLY FIRE HAZARD INDICES	
Ignition index	0
Flame spread index	0
Heat evolved index	0
Smoke developed index	0 - 1

NOTES: Zero is the best possible result. The range is 0 - 10, except Ignition Index which is 0 - 20.

Alpine regions

In regions subject to freeze/thaw conditions, James Hardie external cladding must be painted. In addition, the cladding must not be in direct contact with snow/or ice build up for extended periods, e.g. external walls in alpine regions subject to snow drifts over winter.

Tested to AS/NZS 2908.2 Clause 8.2.3

WARRANTY

James Hardie Australia Pty Limited ("James Hardie") warrants to the first purchaser of the Product and the last purchaser prior to the installation of the Product for a period of 10 years from the date of purchase that the Matrix™ panel and Scyon™ cavity trim (the "Product(s)") will be free from defects due to defective factory workmanship or materials and, subject to compliance with the conditions below, will be resistant to cracking, rotting, fire and damage from termite attacks to the extent set out in James Hardie's relevant published literature current at the time of installation. James Hardie warrants for a period of 12 months from the date of purchase that the accessories supplied by James Hardie will be free from defects due to defective factory workmanship or materials.

Nothing in this document shall exclude or modify any legal rights a customer may have under the Trade Practices Act or otherwise which cannot be excluded or modified at law.

Conditions of warranty

The warranty is strictly subject to the following conditions:

- a) James Hardie will not be liable for breach of warranty unless the claimant provides proof of purchase and makes a written claim either within 30 days after the defect would have become reasonably apparent or, if the defect was reasonably apparent prior to installation, then the claim must be made prior to installation;
- b) this warranty is not transferable;
- c) the Product must be installed and maintained strictly in accordance with the relevant James Hardie literature current at the time of installation and must be installed in conjunction with the components or products specified in the literature. To obtain copies of such literature contact Ask James Hardie™ on 13 11 03. Further, all other products, including coating and jointing systems, applied to or used in conjunction with the Product must be applied or installed and maintained strictly in accordance with the relevant manufacturer's instructions and good trade practice;
- d) the project must be designed and constructed in strict compliance with all relevant provisions of the current Building Code of Australia, regulations and standards;
- e) the claimant's sole remedy for breach of warranty is (at James Hardie's option) that James Hardie will either supply replacement product, rectify the affected product or pay for the cost of the replacement or rectification of the affected product;

- f) James Hardie will not be liable for any losses or damages (whether direct or indirect) including property damage or personal injury, consequential loss, economic loss or loss of profits, arising in contract or negligence or howsoever arising.

Without limiting the foregoing, James Hardie will not be liable for any claims, damages or defects arising from or in any way attributable to poor workmanship, poor design or detailing, settlement or structural movement and/or movement of materials to which the Product is attached, incorrect design of the structure, acts of God including but not limited to earthquakes, cyclones, floods or other severe weather conditions or unusual climatic conditions, efflorescence or performance of paint/coatings applied to the Product, normal wear and tear, growth of mould, mildew, fungi, bacteria, or any organism on any Product surface or Product (whether on the exposed or unexposed surfaces);

- g) all warranties, conditions, liabilities and obligations other than those specified in this warranty are excluded to the fullest extent allowed by law;
- h) if meeting a claim under this warranty involves re-coating of Products, there may be slight colour differences between the original and replacement Products due to the effects of weathering and variations in materials over time.

DISCLAIMER

The recommendations in James Hardie's literature are based on good building practice, but are not an exhaustive statement of all relevant information and are subject to conditions (c), (d), (f) and (g) above. Further, as the successful performance of the relevant system depends on numerous factors outside the control of James Hardie (eg quality of workmanship and design), James Hardie shall not be liable for the recommendations in that literature and the performance of the relevant system, including its suitability for any purpose or ability to satisfy the relevant provisions of the Building Code of Australia, regulations and standards.

For more information please Ask James Hardie™ on 13 11 03 or visit www.jameshardie.com.au

Ask James Hardie™
Call 13 11 03
www.jameshardie.com.au

COPYRIGHT SEPTEMBER 2008
© JAMES HARDIE AUSTRALIA PTY LTD ABN 12 084 635 558
™ AND ® DENOTES A TRADEMARK OR REGISTERED MARK
OWNED BY JAMES HARDIE INTERNATIONAL FINANCE BV.